

# RS 232 communication

**Configuration**  
**Vestas VMP3500**

## 1. Table of contents

1. Table of contents.....	2
2. Introduction.....	3
3. Vestas turbines (RCS).....	4
3.1. VMP 3500 controller .....	4
3.2. Communication with the CT3230 current loop board. ....	5
3.3. Configuration of the WICotech Current loop driver .....	6
3.4. Connection of WICotech current loop driver to Vestas .....	8
3.4.1. Directly to the CT3230 module .....	8
3.4.2. Via the yellow lightning protection units .....	9
3.4.3. Signal flow though the WICotech driver.....	10
4. Cables .....	12
4.1. Cable layout for F2403 to WICotech driver .....	12
4.2. FourFaith F2403 to CT 3212 module .....	12
4.3. Cable layout for F2816 - COM 1 to WICotech driver.....	13
4.4. Cable layout for F2816 - COM 2 to WICotech driver.....	13
5. Four Faith Signal monitoring.....	14
5.1. F2403 Signal monitoring .....	14
5.2. F2816 Signal monitoring .....	15

## **2. Introduction**

This document shows how to enable RS232 communication on a Vestas VMP3500.

The document includes:

- How to change parameter and which settings needs to be changed.
- Hardware updates and changes.
- What new hardware is needed.
- Cable connections.

## 3. Vestas turbines (RCS)

### 3.1. VMP 3500 controller



The following parameters must be configured to get a Vestas VMP3500 controller to communicate over the current loop:

- |                           |          |                                |
|---------------------------|----------|--------------------------------|
| ▪ RCS number              | 1        | (Can be between 1 to 255)      |
| ▪ Communication baud rate | 4800     | (Can be between 1200 and 9600) |
| ▪ Communication parity    | 0 (None) |                                |
| ▪ Communication mode      | 205      |                                |

This is how to change parameters in the controller:

- Press “MENU” then “FUNC” the password 246 and “ENTER”
- Press 24 “ENTER” to enter parameter menu
- Scroll down to line 12 (RCS) and press “ENTER”
- Scroll down to line 1 (Communication mode) press “FUNC” 205 “ENTER”
- Scroll down to line 2 (Baud rate) press “FUNC” 4800 “ENTER” (Baudrate: 4800)
- Scroll down to line 3 (Parity) press “FUNC” 0 “ENTER”
- Press “\*” “ENTER” to activate new parameters
- Press “MENU” to step one menu level back
- Scroll down to line 14 (Miscellaneous) “ENTER”
- Scroll down to line 4 (RCS number) press “FUNC” 1 “ENTER” (Id number: 1)
- Press “\*” “ENTER” to activate new parameter
- Press “MENU” twice
- Press 1 “ENTER”

The communication is now set to 4800 8N1 using id 1.

Depending on the loop size and quality can the communication speed be set to between 1200 and 9600. This has to be tested on site.

## 3.2. Communication with the CT3230 current loop board.

The communication between the main processor board CT3503 and the CT3230 current loop module is protocol based. This means that the main processor is communicating internally with the sub-processor in the CT3230 module.

Sometimes is this communication not working correctly, even though the RxD light is blinking on the front of the CT3230 module.

There is a simple way of verifying if the internal communication is working. This is done by entering into menu 7: "Remote Control". Here is the version of the remote communication interface listed. If this version number is displaying 0.00 is it not talking to the CT module. If it reads a number like 1.04 is it ok.

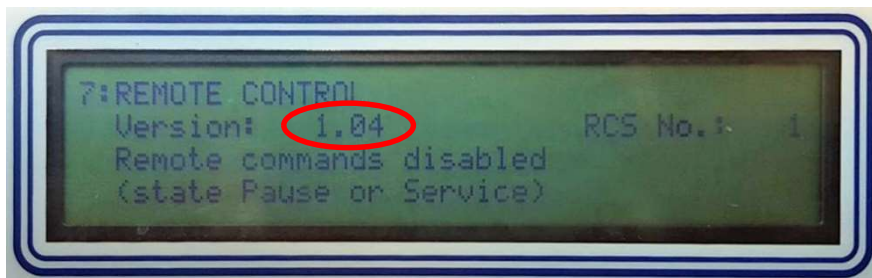

If there is no communication with the CT module will the turbine have to be reinitialized. This procedure is not a part of this manual and can only be done by skilled service technicians.



### 3.3. Configuration of the WICotech Current loop driver

The universal current loop driver from WICotech is used to convert the Vestas loop signals to RS232. This unit uses the same current loop wires as the Telecom I or II.



There are two dip switched that are used to configure the unit:

Dip switch 1:	Loop mode, echo and control signals
Dip switch 2:	Current loop voltage setting.

The switched are located on the left side of the unit.

The current loop plug is located in the top.

The RS232 connector is located in the bottom.

The power plug is located in the bottom. The power plug is used to supply 220 V to the unit. The same plug also gives the possibility to supply an external modem with 24 V from the internal power supply. This is used to feed the Four-Faith F2403 GPRS modem supplied by PS-Data.

## RS 232 communication

---

Dip switch settings:

**Dip switch 1:** Default: Dip 1, 2 and 4 is ON and 3 and 5 is off.

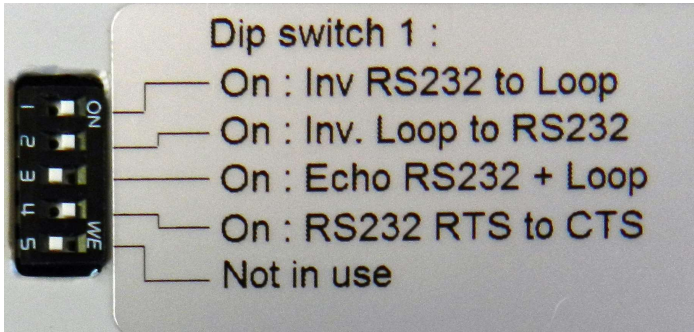

Dip 1 and 2 inverts the signal levels on the current loop. This must be on when communicating on a Vestas current loop.

Dip 3 is used to remove echo on the loop. If this setting is on will all questions send out on the loop be echoed back to the sender. This setting is normally off on a Vestas current loop

Dip 4 is used to short RTS and CTS in the RS232 connector. This setting is normally on.

Dip 5 is not used.

**Dip switch 2:** Default: Dip 2 is ON and the rest is off.

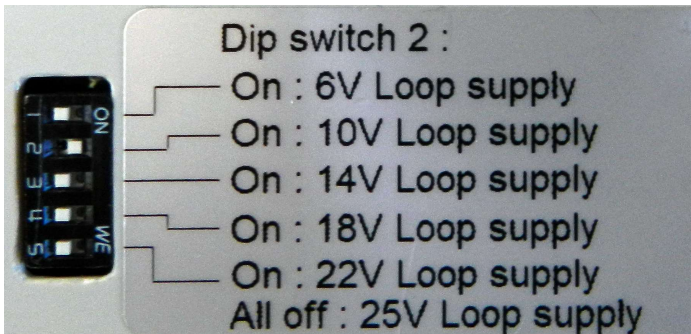

Dip switch 2 is used to set the voltage on the current loop.

Default current loop voltage is 10 V (Dip 2 on)

If the loop LED lights does not light up clearly try to raise the voltage one step to see if it helps. Be aware that the voltage should be kept as low as possible, since this gives the best change of high communication speeds.

## 3.4. Connection of WICotech current loop driver to Vestas

The WICotech current loop driver can be connected to the WMP controller in two ways:

1. Directly to the CT2130/CT3230 module
2. Via the yellow lightning protection units.

Option one is typically used in single turbines and option 2 is used when there is more than one turbine in the park (Connected on the same current loop cable)

### 3.4.1. Directly to the CT3230 module

This cable connects the current loop driver directly to the round connector on the CT3230.

WICotech	CT Connector
Pin 1 Yellow	Pin 1 Yellow
Pin 2 Green	Pin 2 Green
Pin 5 Brown	Pin 4 Rosa
Pin 6 Beige	Pin 5 Gray

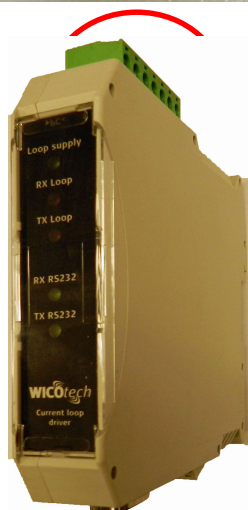
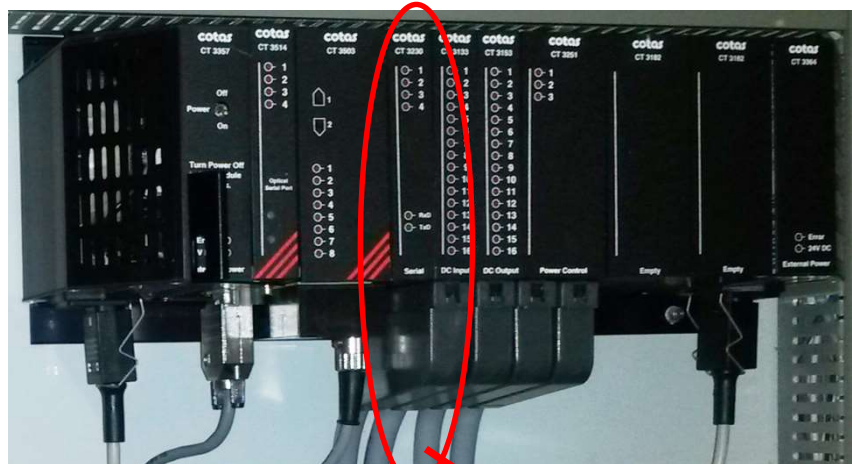
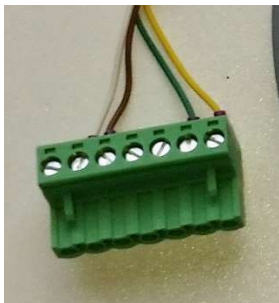

## 3.4.2. Via the yellow lightning protection units

The WICotech current loop converter is connected to the Turbines current loop system on yellow the lightning unit mounted on the din rail in the panel with the phase compensation (Together with the Telecom)

The Telecom must be disconnected.

The four current loop cables are mounted using the cable delivered together with the WICotech current loop driver. It has to be connected to the four connectors on top of the yellow lightning protection unit as displayed in the figure below.

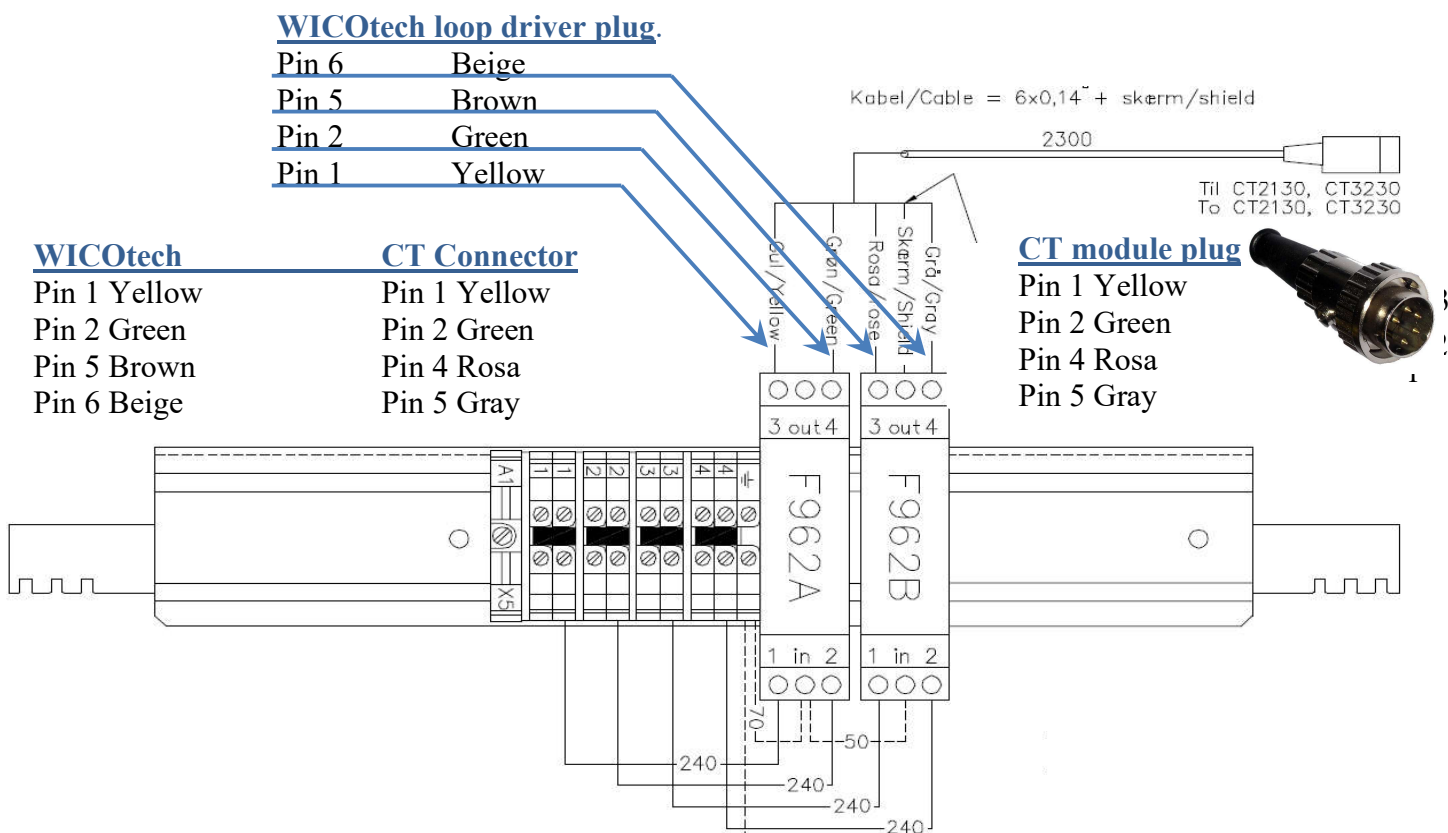

\*) Jordskrue i kondensatorsektion/  
Earth screw in capacitor section.

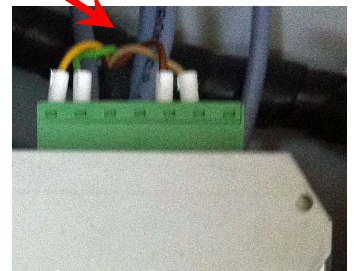
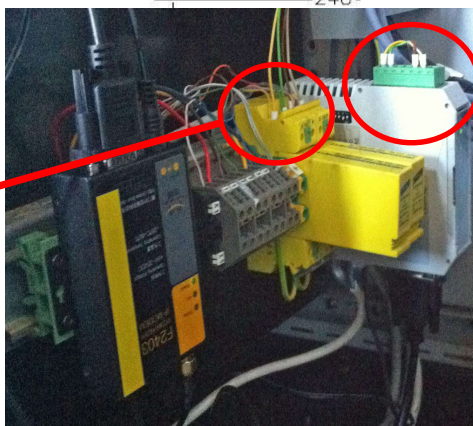
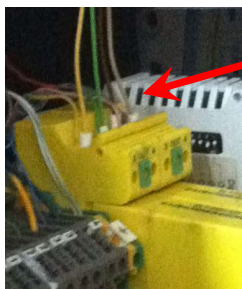

## 3.4.3. Signal flow through the WICotech driver

This chapter describes the signal flow through a WICotech current loop driver to the CT3230 module on the VMP3500.

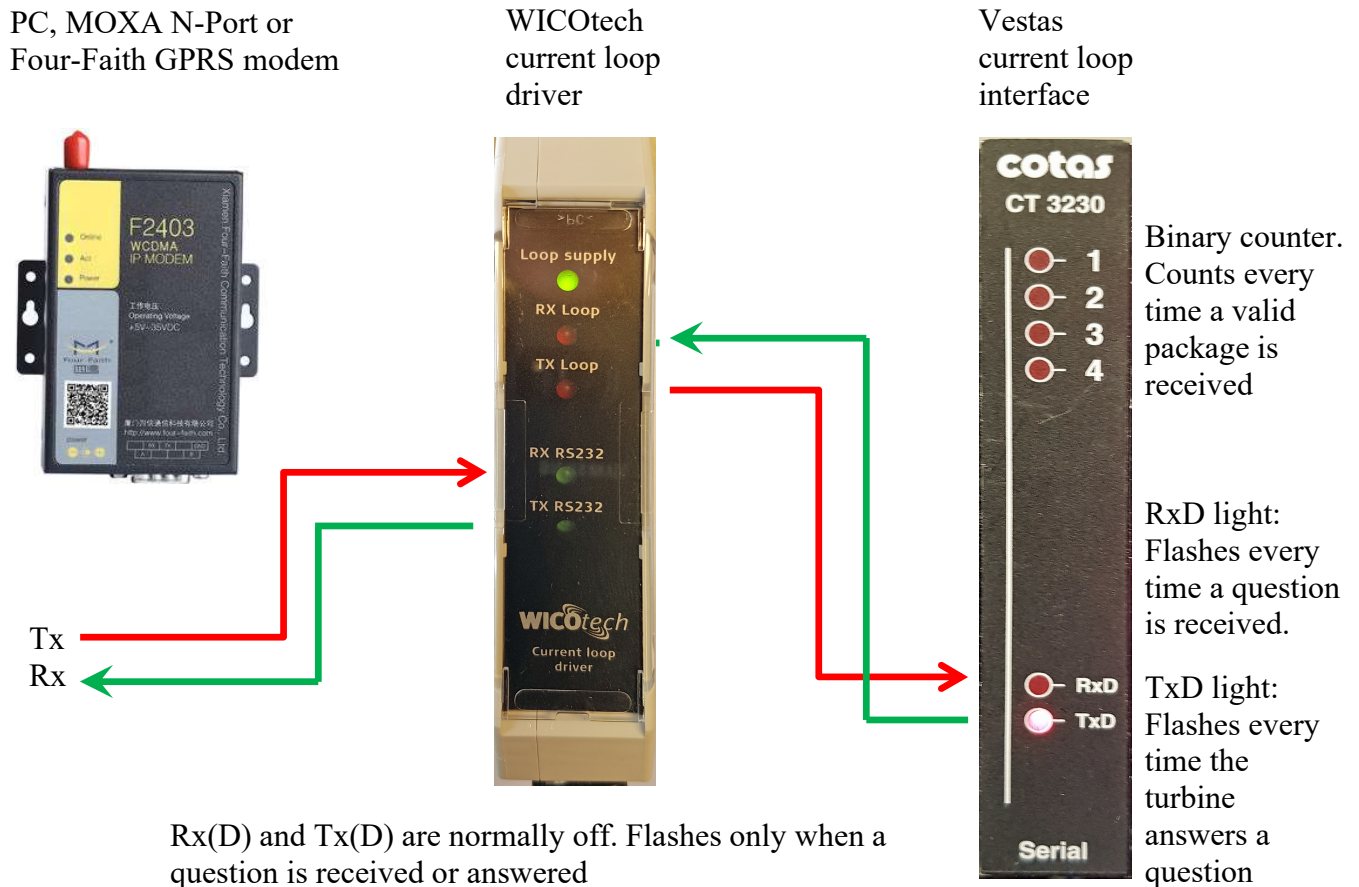

A question from the modem (server) is sent through the red line and the answer is returned through the green line. The LED's will flash in the following order Rx RS232 -> TX Loop -> RxD and the return flow are TxD -> RX loop -> TX RS232. If the flow is not completed there is a fault in the system and the server does not receive any data.

There are a number of failure points.

1. GPRS modem (including baudrate, databit, parity and stopbit)
2. RS232 cable
3. WICotech current loop driver (including dip switches)
4. Current loop cables
5. CT 3220 communication interface
6. Parameters in the turbine.

The two most common errors are loop wiring problems (Or broken wires) or defect CT module, but it can in rare cases also be the WICotech current loop driver or the GPRS modem.

## RS 232 communication

---

Here is a list of standard scenarios when searching for an error in the system:

If the CT3230 module receives the RxD light is the transmit line (Red line) typically ok.

If the CT3230 module answers the TxD light normally flashes. If the turbine receives a question but does not answer is it typically a problem with:

1. Communication parameters in the GPRS modem
2. The parameters or the RCS number in the turbine

If the CT3230 module does not receive any packages (RxD does not flash), but the Rx RS232 light (WICotech module) flashes there is a problem with the current loop. Please check:

1. Check loop wires (between CT3230 and current loop driver)
2. Check dip switches on the WICotech module
3. Replace CT3220 module
4. Replace WICotech driver

If the CT3230 module does not receive any packages (RxD does not flash) and the Rx RS232 light (WICotech module) does not flash there is a problem with the RS232 side. Please check:

1. Is the server configured and sending questions
2. Check RS232 cable
3. Replace WICotech driver (Check dip switches)
4. Replace GPRS modem

If the CT3230 module answers (TxD flashes), but the WICotech modules Rx loop driver led is not flashing. Please check:

1. Loop wires (between CT3230 and current loop driver)
2. Check dip switches on the WICotech module
3. Replace C3220 module
4. Replace WICotech driver

If the CT3230 module answers (TxD flashes) and the Rx Loop flashes, but the WICotech modules Rx RS232 driver led is not flashing. Please check:

1. Loop wires (between CT3230 and current loop driver)
2. Check dip switches on the WICotech module
3. Replace WICotech driver

#### 4. Cables

##### 4.1. Cable layout for F2403 to WICOtech driver

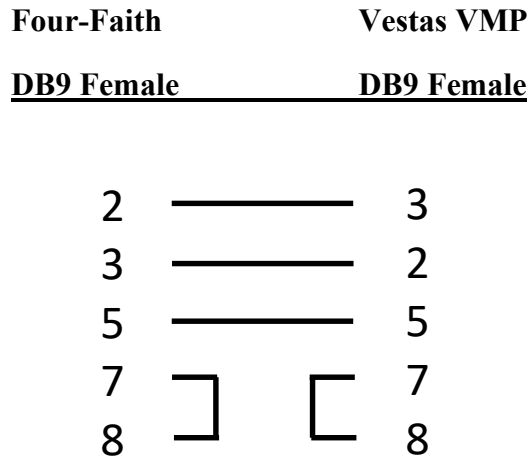

Same as the standard Four-Faith (Black) communication cable.

##### 4.2. FourFaith F2403 to CT 3212 module

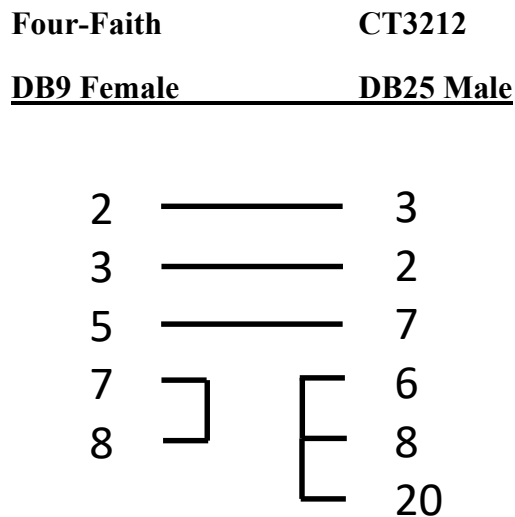

**4.3. Cable layout for F2816 - COM 1 to WICOtech driver**

Four-Faith 2816		Vestas VMP	
<u>Terminal</u>		<u>DB9 Female</u>	
3	————	3	White
4	————	2	Green
5	————	5	Brown
1 PWR		7	
2 GND		8	

**4.4. Cable layout for F2816 - COM 2 to WICOtech driver**

Four-Faith 2816		Vestas VMP	
<u>Terminal</u>		<u>DB9 Female</u>	
6	————	3	White
7	————	2	Green
5	————	5	Brown
1 PWR		7	
2 GND		8	

The Power (PWR) must be between +5V to +36V DC (Standard power supply is 12V DC)

An easy way to check if the wires on pin 3 and 4 (COM1) or pin 6 and 7 (COM2) is mounted correct is to measure the DC voltage on both pins in reference to GND (pin 5). If the Rx and Tx wires are mounted correct, should it be possible to measure a voltage on both pins (Above 3 volts). If there is only voltage on one pin is the wires wrong and they must be flipped.

## 5. Four Faith Signal monitoring

### 5.1. F2403 Signal monitoring

The Four Faith F2403 GPRS modem can be used to monitor the signal strength during installation.

This can be done on units bought after October 2014 and with firmware versions after this date.

The Signal mode is activated using a special DB9 adaptor that is inserted into the RS232 port on the Four Faith modem. When the adaptor is inserted will the online LED on the modem not display the online status anymore but instead will the signal strength be display. The signal level is illustrated by a number of blinks that is repeated every 3 seconds.

There are 5 different blink levels.

Level	Signal strength (dBm)	Quality
1	-113 -> -103	Bad
2	-101 -> -95	Marginal
3	-93 -> -85	OK
4	-83 -> -75	Good
5	-73 or higher	Excellent



The GPRS modem will not attempt to connect unless the signal strength is 2 or above but the signal should be no less than 3 or more before a stable connection can be expected.

Be aware that when the Signal tester adaptor is inserted will the modem NOT attempt to go online. The modem will return to normal operation when the adaptor is removed.

## 5.2. F2816 Signal monitoring

The Four Faith F2816 GPRS modem can be used to monitor the signal strength during installation.

The Signal mode is activated by pressing the signal tester button on the “Multiport interface” unit. The button has to be kept pressed during the signal testing.

If the kit is not equipped with the signal tester button can the signal mode be activated by connecting pin 11 (IO2) to the ground pin 2 or 5.

When the connection is established will the online LED on the modem not display the online status anymore but instead will the signal strength be display. The signal level is illustrated by a number of blinks that is repeated every 3 seconds.

There are 5 different blink levels.

Level	Signal strength (dBm)	Quality
1	-113 -> -103	Bad
2	-101 -> -95	Marginal
3	-93 -> -85	OK
4	-83 -> -75	Good
5	-73 or higher	Excellent



The GPRS modem will not attempt to connect unless the signal strength is 2 or above but the signal should be no less than 3 or more before a stable connection can be expected.

Be aware that when the Signal tester is active will the modem NOT show the online signal anymore. The modem will return to normal operation when the adaptor is removed.